

450x450  
VILLAGE STONE  
COLUMN BLOCKS

(A)

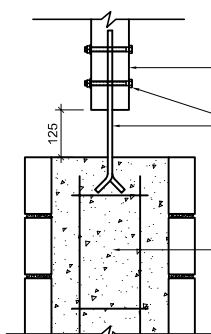

100x100 H3.2 Timber Post

Galv. Bowmac post bracket  
2 M12 bolts

125

vibrate concrete fill when  
placing concrete in column,  
make sure column sections  
do not blow apart.

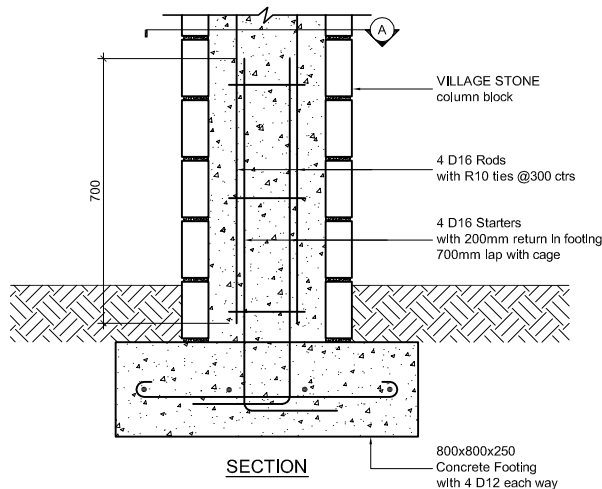

VILLAGE STONE  
column block

4 D16 Rods  
with R10 ties @300 ctrs

4 D16 Starters  
with 200mm return in footing  
700mm lap with cage

700

SECTION

800x800x250  
Concrete Footing  
with 4 D12 each way

**NOTE: ALL BUILDING MUST COMPLY WITH NZS 3604: 1999 AND THE NEW ZEALAND BUILDING CODE**

Technical Disclaimer: This information is intended solely as a guide for use of Village Stone products. Before using Village Stone product you should ensure that the product is suitable for use in the specific application. Nothing in this information constitutes a statement of fitness for particular purpose - appropriate expert advice should always be obtained. Village Stone makes no warranty regarding the use of this information with non-Village Stone product.  
© Village Stone, New Zealand.



## VILLAGE STONE VENEER DETAILS

### Column Detail

scale 1:20

SK11